

# GROUP 25 - BODY FRAMING AND MOUNTING 25-1

## Group 25

# BODY FRAMING AND MOUNTING

### Contents

<b>Title</b>	<b>Section Page</b>	
Cowl and Windshield Frame Opening Assembly	25-1	25-2
Underbody Frame Side Rails	25-2	25-3
Roof Panel	25-3	25-3
Lower Deck Panel	25-4	25-3
Side Frame	25-5	25-4
Mounting - Body 120" WB	25-6	25-6
Mounting - Body 129" WB	25-7	25-6
Mounting - Body	25-8	25-7

**GROUP 25 - BODY FRAMING AND MOUNTING 25-2**

A	A	A	A
11	11	12	12
	E		E

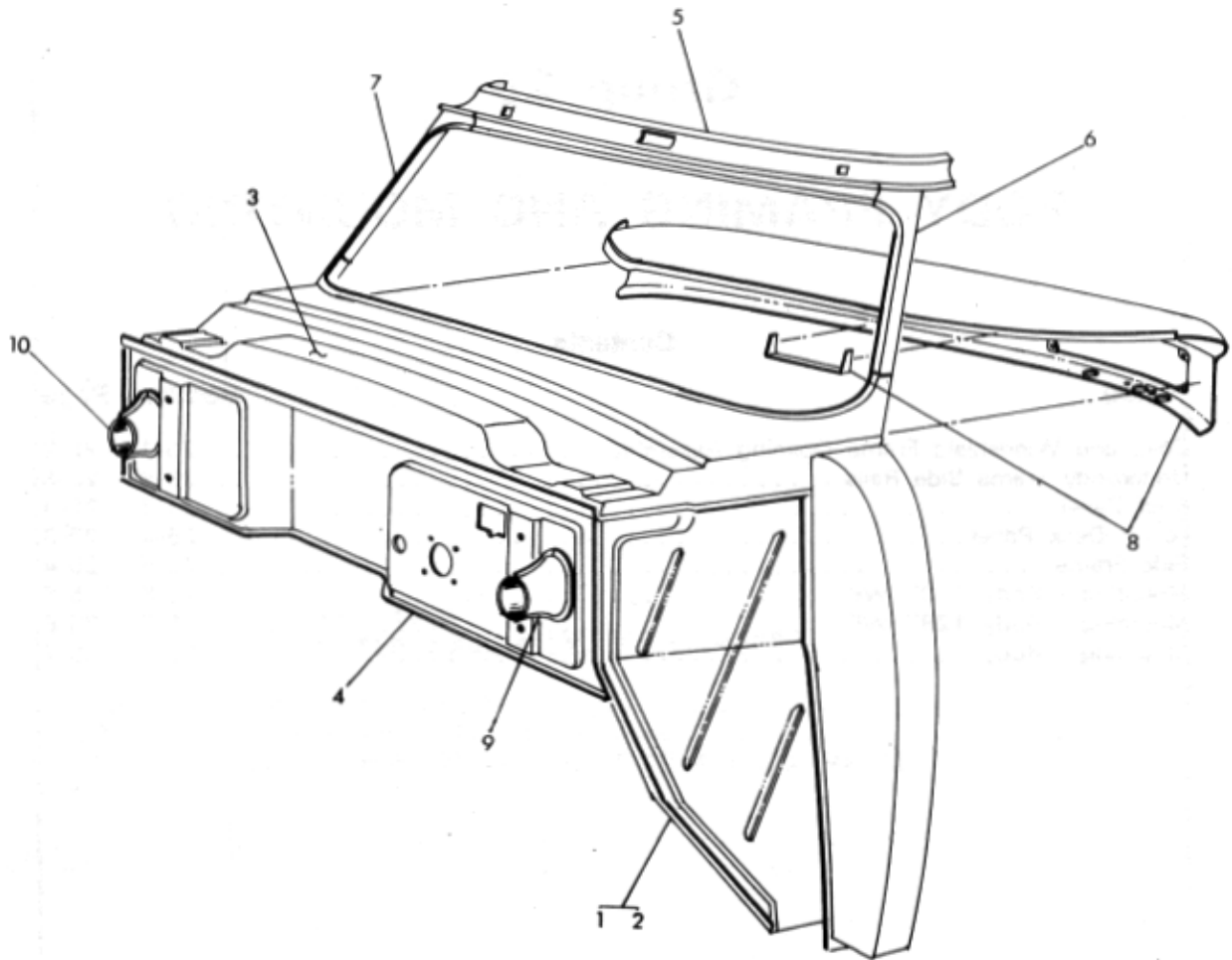

*Figure 25-1 Cowl and Windshield Frame Opening Assembly*

## GROUP 25 - BODY FRAMING AND MOUNTING 25-3

Item	Part Number	Description	Qty
<b>Figure 25-1</b>			
<b>COWL AND WINDSHIELD FRAME OPENING ASSEMBLY</b>			
1	651709	Cowl Side & Pillar Asm. - LH	1
2	651710	Cowl Side & Pillar Asm. - RH	1
3	653203	Panel Asm. - Cowl Top	1
4	647042	Panel Asm. - Dash (Includes Air Ducts 9 & 10)	1
5	653121	Panel & Nut Asm. - W/S Opening Inner Frame - Top	1
6	644377	Panel - LH	1
7	644378	Panel - RH	1
8	647927	Panel Asm. - Instrument	1
9	633079	Connector Asm. - Air Duct LH	1
10	647980	Connector Asm. - Air Duct RH	1
	633080	Damper & Seal Asm. - Air Duct	2
	626901	Shaft - Damper	2
	626409	Nut (3/16 Push On)	2
<b>Section 25-2</b>			
<b>UNDERBODY FRAME SIDE RAILS</b>			
	630165	Rail Asm. - Floor Side - LH(120" WB)	1
	630166	Rail Asm.- Floor Side - RH (120"WB)	1
	641123	Rail Asm.- Floor Side - LH (129"WB)	1
	641124	Rail Asm.- Floor Side - RH (129"WB)	1
<b>Section 25-3</b>			
<b>ROOF PANEL</b>			
	645528	Panel Asm. - Roof Complete (120" WB)	1
	644399	Deadener - Roof Panel	1
	645512	Panel Asm. - Roof Complete (129" WB)	1
	644399	Deadener - Roof Panel	1
	641032	Moulding Asm. - Roof Panel	1
	640459	Weatherseal - Roof Moulding	1
	626403	Nut, Washer & Seal (1/4-20) (Above * All E Only)	7
<b>Section 25-4</b>			
<b>LOWER DECK PANEL</b>			
	653273	Panel Asm. - Deck Lower & Cross Sill	1
	646976	Panel - Rear Cross Sill	1
	651660	Bracket Asm. - Deck Lid Lock Striker Mounting	1

**GROUP 25 - BODY FRAMING AND MOUNTING 25-4**

A	A	A	A
11	11	12	12
	E		E

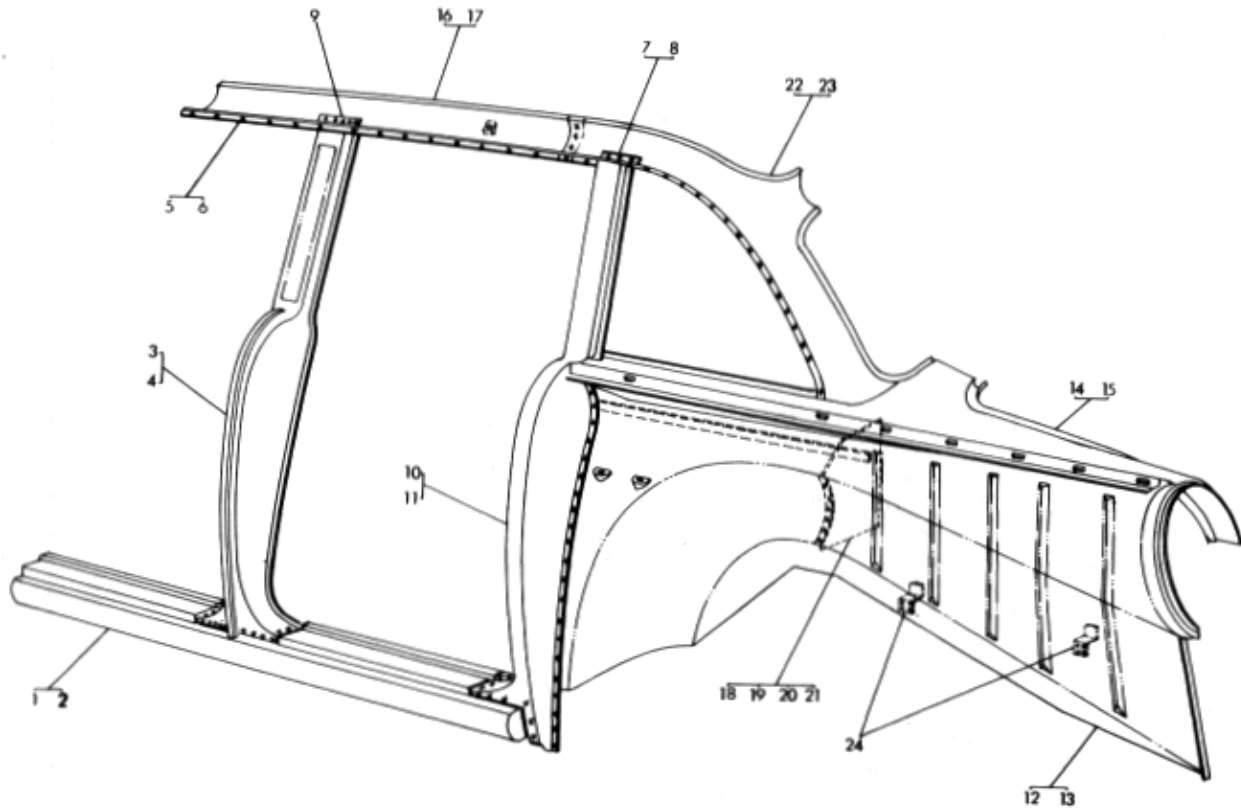

*Figure 25-5 Side Frame*

## GROUP 25 - BODY FRAMING AND MOUNTING 25-5

Item	Part Number	Description	Qty
		Figure 25-5 SIDE FRAME	
1	634007	Panel - Sill - LH (120" WB)	1
2	634008	Panel - Sill - RH (120" WB)	1
	641125	Panel - Sill - LH (129" WB)	1
	641126	Panel - Sill - RH (129" WB)	1
3	651703	Pillar Asm. - Center - LH	1
4	651704	Pillar Asm. - Center - RH	1
5	645855	Rail Asm. - Roof - LH (120" WB)	1
6	645856	Rail Asm. - Roof - RH (120" WB)	1
	645857	Rail Asm. - Roof - LH (129" WB)	1
	645858	Rail Asm. - Roof - RH (129" WB)	1
7	634275	Channel - Rear Pillar - LH	1
8	634276	Channel - Rear Pillar - RH	1
9	634129	Channel - Center Pillar	2
10	651701	Pillar Asm. - Rear - LH	1
11	651702	Pillar Asm. - Rear - RH	1
12	642635	Panel - Rear Wheelhouse - LH	1
13	642636	Panel - Rear Wheelhouse - RH	1
14	634027	Panel - Rear Quarter - LH	1
15	634028	Panel - Rear Quarter - RH	1
16	630029	Reinf. - Roof - LH (120" WB)	1
17	630030	Reinf. - Roof - RH (120" WB)	1
	641133	Reinf. - Roof - LH (129" WB)	1
	641134	Reinf. - Roof - RH (129" WB)	1
18	634039	Support - Shelf Panel - LH	1
19	634040	Support - Shelf Panel - RH	1
20	638037	Support - Shelf Panel - LH RSF (120" WB)	1
21	638038	Support - Shelf Panel - RH RSF (120" WB)	1
22	645545	Panel & Retainer - LH	1
23	645546	Panel & Retainer - RH	1
24	642653	Clip - Jack Mounting (RH Side Only)	2

**GROUP 25 - BODY FRAMING AND MOUNTING 25-6**

A		A	
11		12	

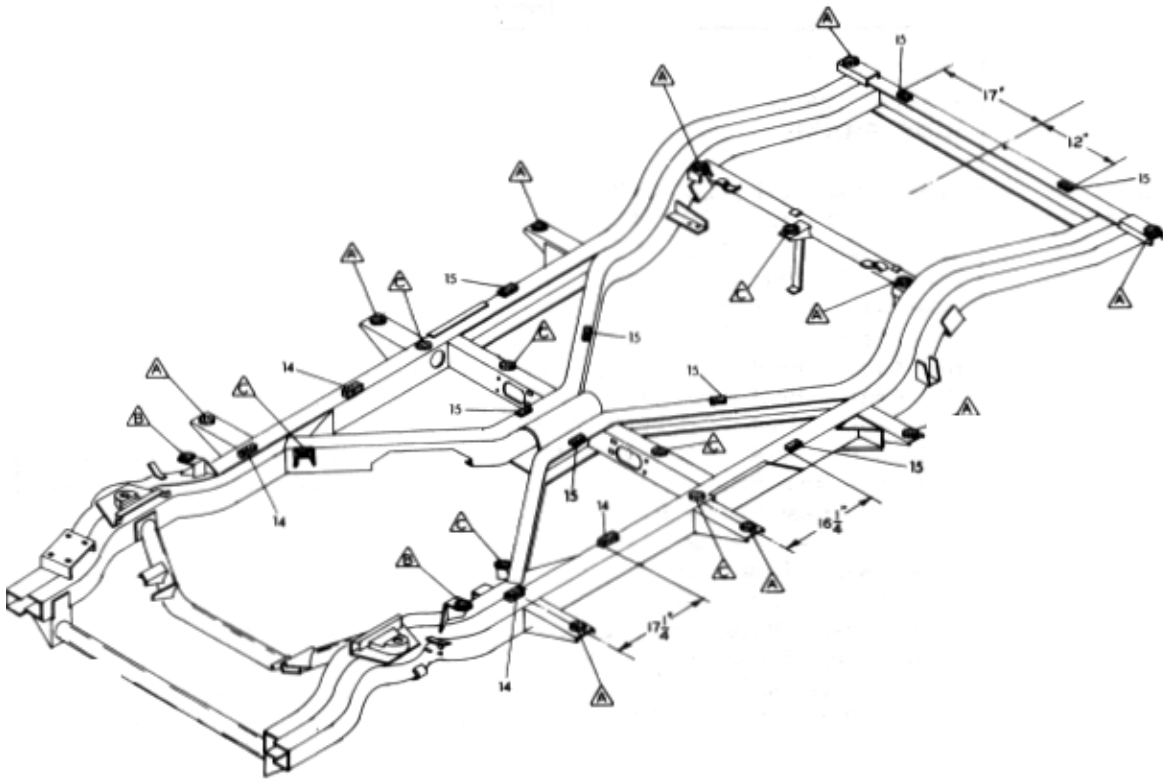

*Figure 25-6 Mounting .Body 120" WB*

	A		A
	11		12
	E		E

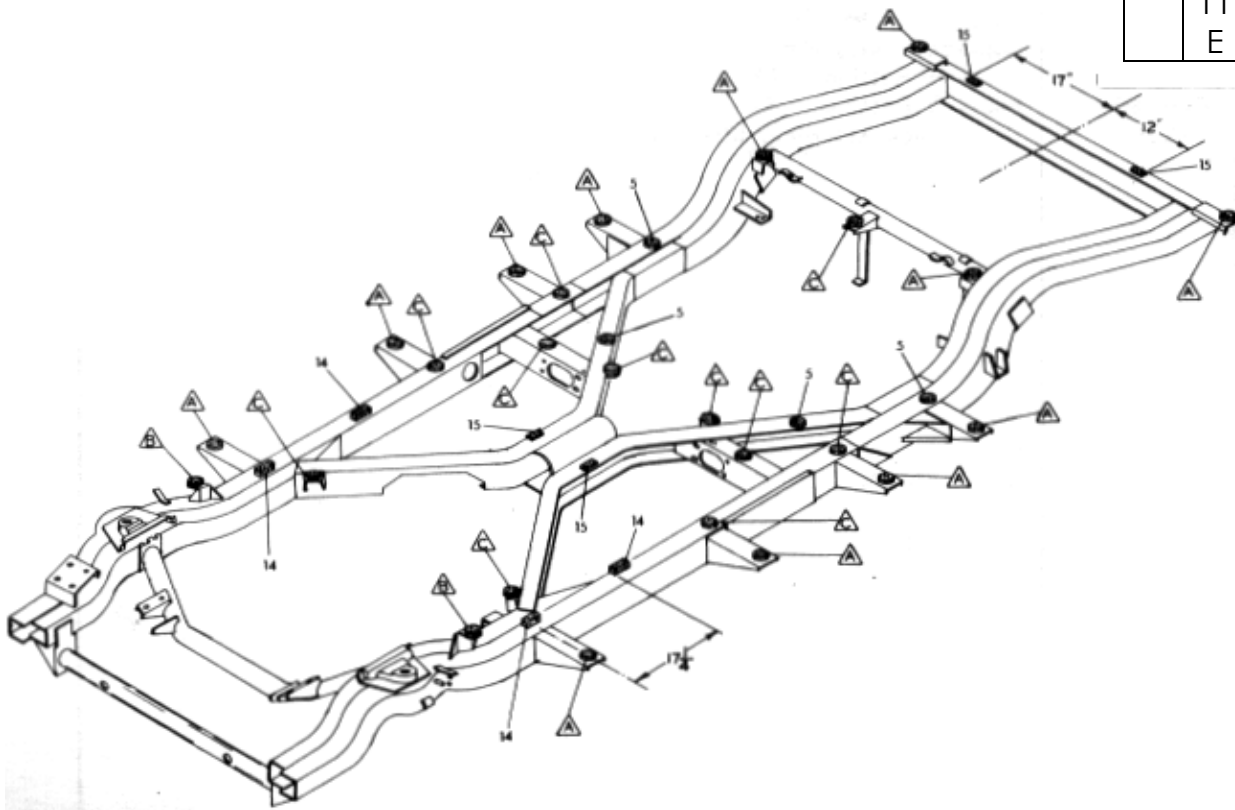

*Figure 25-7 Mounting .Body 129" WB*

**Checker Motors Corp.**

## GROUP 25 - BODY FRAMING AND MOUNTING 25-7

- ⚠ TIGHTEN FIRST, STARTING AT FRONT
  - ⚠ TIGHTEN SECOND, USING SPACERS (10) AS REQD
  - ⚠ TIGHTEN LAST
- TIGHTEN ALL BODY MTG. NUTS TO 16-20 FT. LBS. TORQUE

A	A	A	A
11	11	12	12
	E		E

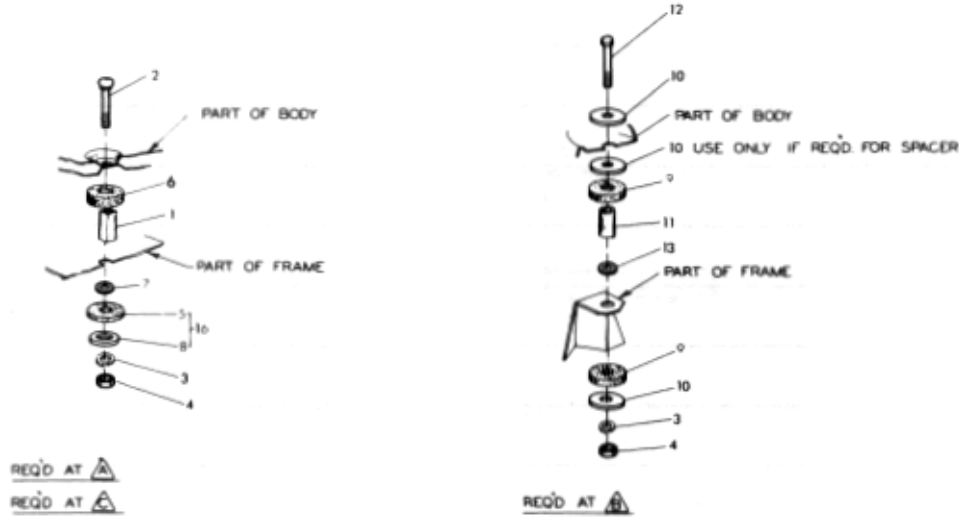

*Figure 25-8 Mounting Body*

Item	Part Number	Description	Qty
Figure 25-8 MOUNTING - BODY			
1	94550	Spacer 120" WB	17
	94550	Spacer 129" WB	23
2	94570	Bolt (3/8-16 X 2 1/2 Step)120" WB	17
	94570	Bolt (3/8-16 X 2 1/2 Step)129" WB	23
3	120382	LW (3/8 Med. Spring) 120" WB	19
	120382	LW (3/8 Med. Spring) 129" WB	25
4	120377	Nut (3/8-16 Hex) 120" WB	19
	120377	Nut (3/8-16 Hex) 129" WB	25
5	702417	Insulator - Lower 120" WB	17
	702417	Insulator - Lower 129" WB	27
6	702416	Insulator - Upper 120" WB	17
	702416	Insulator - Upper 129" WB	23
7	702415	Washer 120" WB	17
	702415	Washer 129" WB	23
8	446477	Washer (7/16 ID X 1 3/8 OD) 120" WB	17
	446477	Washer (7/16 ID X 1 3/8 OD) 129" WB	23
9	92196	Insulator	4
10	92198	Washer	4
11	92197	Spacer	2
12	180132	Bolt (3/8-16 X 2 1/4 Hex)	2
13	704837	Washer	2
14	94620	Shim (1 1/4 X 1 1/4 X 2)	4
15	94621	Shim (1/2 X 1 X 2) 120" WB	8
	94621	Shim (1/2 X 1 X 2) 129" WB	4
16	705466	Insulator Asm	1