

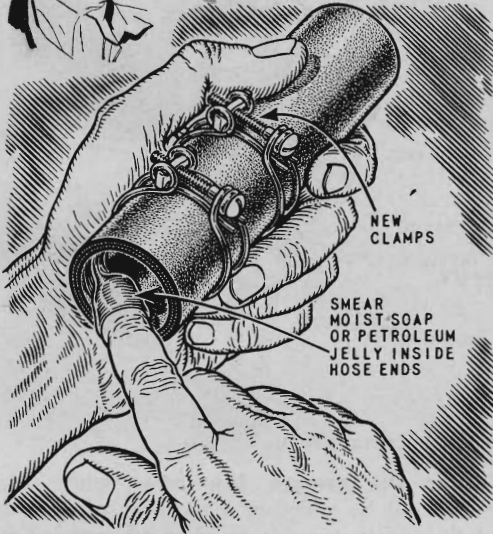

Hints FROM THE MODEL GARAGE

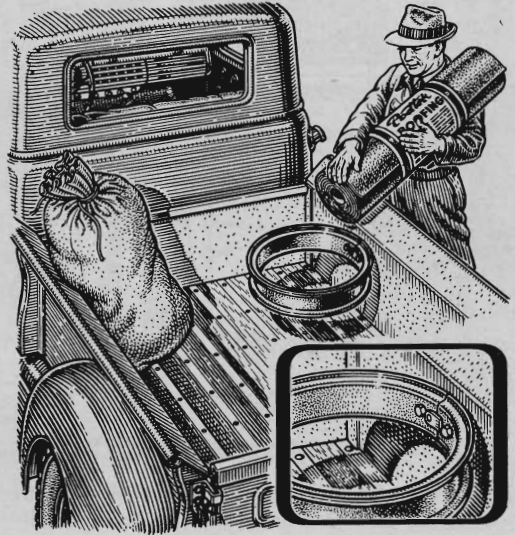

Rub soap inside hose ends when installing new connections between the radiator and motor block. They'll slip on the fittings easily and save you much pulling and tugging. For a thorough job, sandpaper the rust off the fittings and use new clamps.



Bolt one or two truck-tire rims to the side of a pickup truck to keep cylindrical objects like oil drums or rolls of roofing from rolling about. Bolt the rims as high up from the floor as the sides will permit to keep the loads from tipping out.

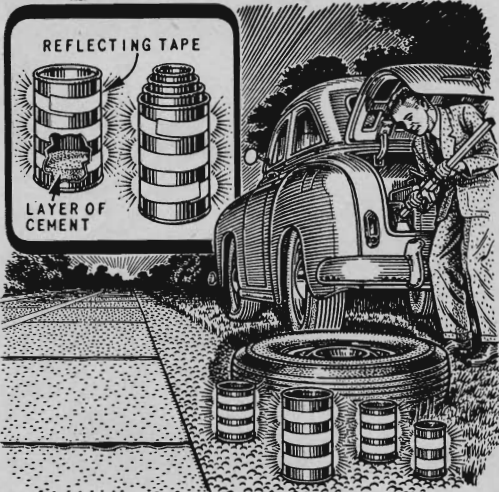

Wrap reflective tape around tin cans to warn passing motorists when you're stuck or changing a tire. Use cans of different sizes so they will nest compactly in the trunk and pour a little cement in the bottom of each can to keep them from blowing over.

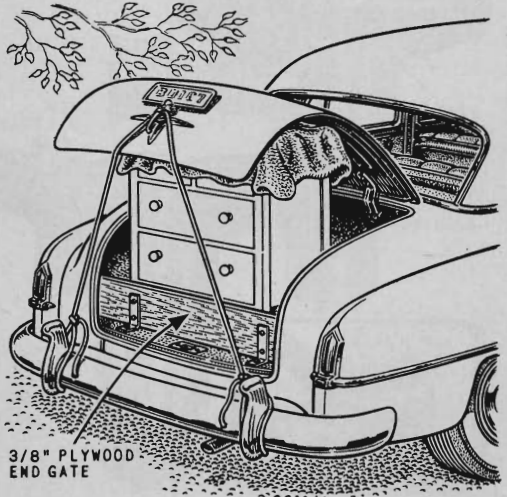

Put a plywood end gate across a low trunk opening to keep tools from rolling out when transporting a large object with the trunk lid up. Set it back far enough so that it won't interfere with the latch and secure it with metal angles bolted to the floor.

MORE Hints from the Model Garage

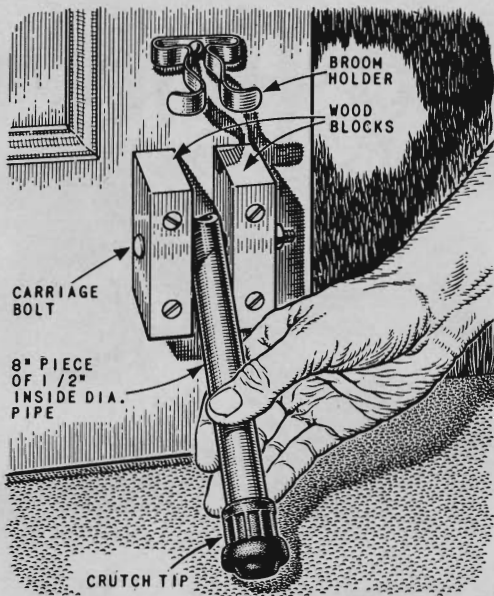
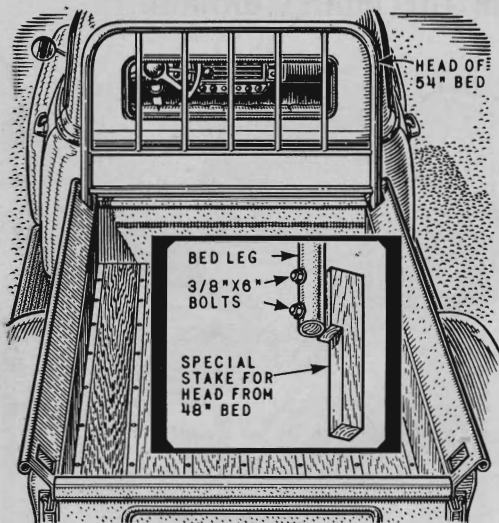

Use the head of an old metal bed to keep the load in a pickup truck from crashing through the rear window when you stop suddenly. Cut a hole in the body sides for the legs. Make the head of a narrow-width bed fit by adding wood extensions (inset).

Keep the garage door open while you back out by pivoting a piece of pipe on a bolt held by two blocks of wood screwed to the inside of the door. A rubber crutch tip keeps it from slipping and a spring clamp stores it up out of the way.

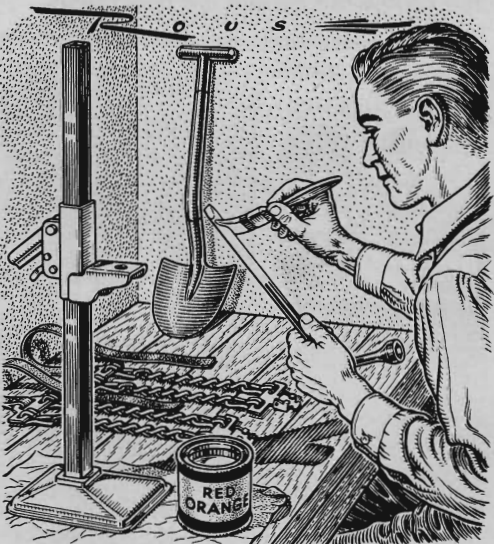
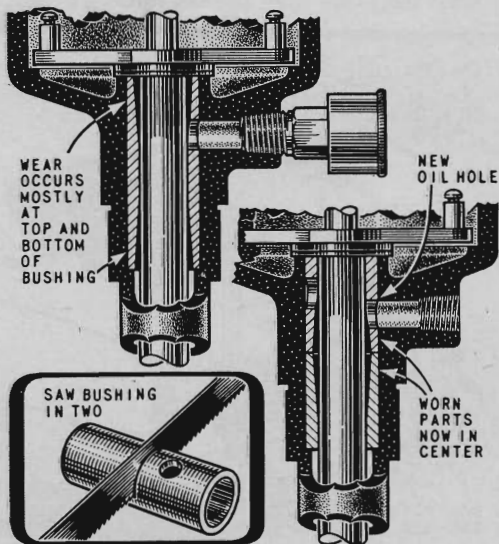

When a distributor bushing wears, play in the shaft affects engine performance. Because most wear is at the bushing ends, you can save fitting a new one if you cut the old bushing in two, drill a new oil hole and put it back with the center sections out.

Paint car tools bright orange or yellow to make them easier to see. Then you'll be less likely to leave them at the roadside when you take them out in snow or at night to change a tire or make repairs. The paint will also keep them free from rust.