

Group 28
REAR EXTERIOR

Contents

Title
Rear Exterior

Section Page
28-1 28-2

GROUP 28 - REAR EXTERIOR - 28-2

A	A	A	A
11	11	12	12
	E		E

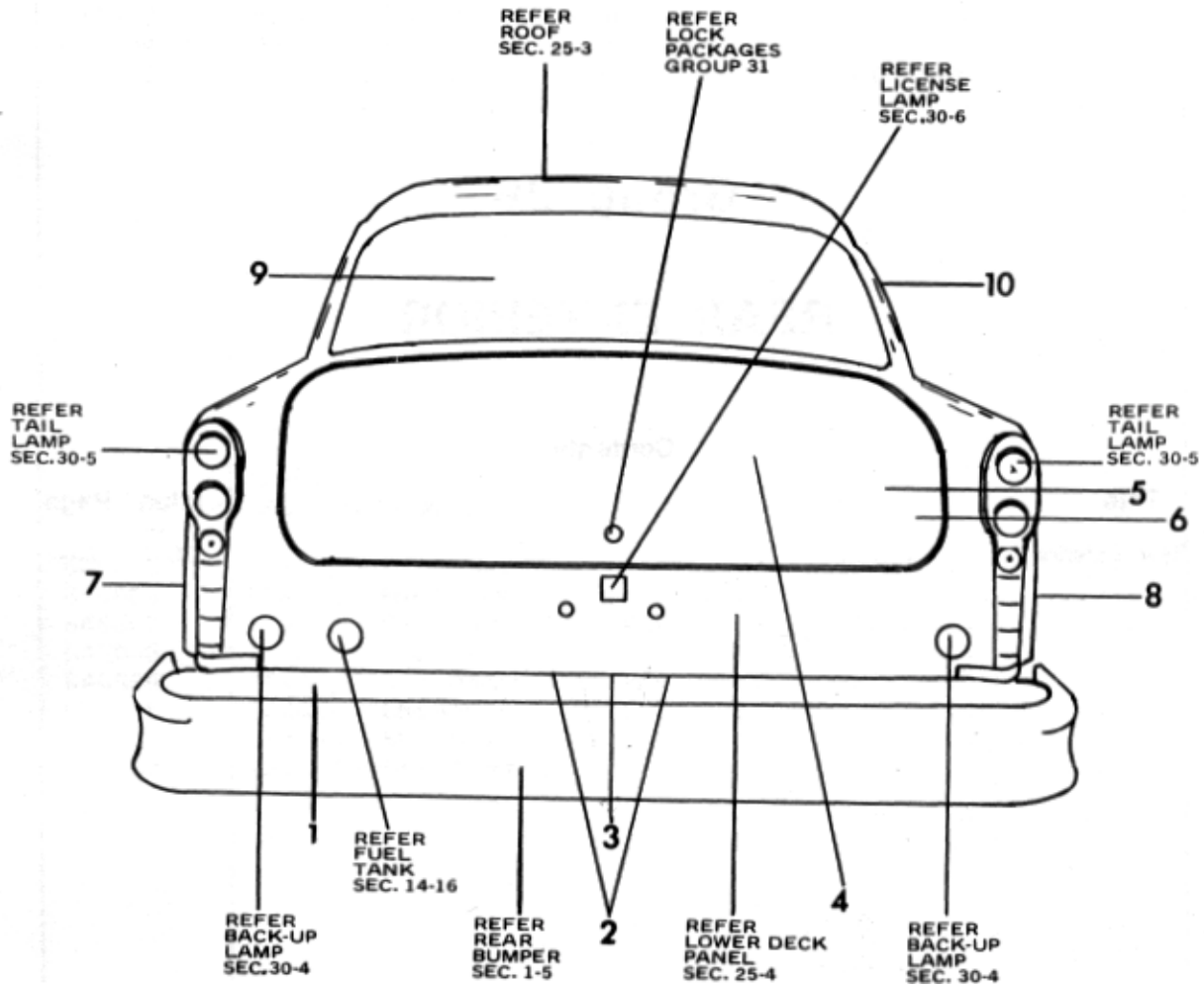

Figure 28-1 Rear Exterior

GROUP 28 - REAR EXTERIOR - 28-3

Item	Part Number	Description	Qty
		Figure 28-1 REAR EXTERIOR	
		REAR SPLASH PANEL INSTALLATION	
1	653150	Panel Asm. - Sight Shield	1
	646878	Gasket - Sight Shield	1
	626642	Rivet (3/16 Pop) Sight Shield Mounting	6
	646682	Support - Rear Splash Extension	1
	174916	Lockwasher (1/4 Int. Ext. Tooth) Support to Body	7
	120854	Bolt (1/4-20 X 5/8 Hex Hd.) Support to Body	7
		LICENSE PLATE MOUNTING - REAR	
2	704682	Grommet - Rear License Plate Mt	1
	9425830	Screw (1/4-14 X 5/8 THCR) License Plate Mounting	2
3	625242	Bumper - License Plate	1
		DECK LID, HINGES AND EMBLEMS INSTALLATION	
4	651666	Deck Lid Asm	1
	651664	Lock Asm. - Deck Lid	1
	646612	Striker - Deck Lid Lock	1
	626449	Screw & Ext. Tooth Lockwasher (1/4-20 X 1/2 Hex Wa. Hd.) Striker Mounting	2
	626449	Screw & Ext. Tooth LW (1/4-20 X 1/2 Hex Wa. Hd.) Lock to Deck Lid	3
	633111	Hinge Asm. - Deck Lid - LH (Std.)	1
	633112	Hinge Asm. - Deck Lid - RH (Std.)	1
	633325	Hinge Asm. - Deck Lid - LH (Hvy. Du.)	1
	633326	Hinge Asm. - Deck Lid - RH (Hvy. Du.)	1
	634850	Spring - Hinge (Standard)	2
	632482	Spring - Hinge (Heavy Duty)	2
	121900	Bolt (1/4-20 X 1 Hex Hd.) Deck Lid to Hinges	4
	120392	Washer (9/32 ID X 5/8 OD Plain) Deck Lid to Hinges	4
	120380	Lockwasher (1/4 Med. Spring) Deck Lid to Hinges	4
	626449	Screw & Lockwasher Asm. (1/4-20 X 1/2 Hex Wa. Hd.) Hinge to Body	6
	626619	Bumper - Deck Lid	2
5	638025	Emblem - Checker	1
6	638026	Emblem - Marathon	1
	626502	Clip - Emblem Mounting	10

GROUP 28 - REAR EXTERIOR - 28-4

Item	Part Number	Description	Qty
		Figure 28-1 REAR EXTERIOR (Cont'd)	
		FENDER INSTALLATION - REAR	
7	647089	Fender Asm. - Rear - LH	1
8	647090	Fender Asm. - Rear - RH	1
	640479	Welt - LH	1
	640480	Welt - RH	1
	634062	Mldg. - Rear Fender Top	2
	634375	Brace - Rear Fender - Front	2
	646661	Brace - Rear Fender - Rear	2
	626290	Retainer Nut ("J" Type) Brace to Fender	4
	626290	Retainer Nut ("J" Type) Fender to Sill	2
	121887	Bolt (1/4-20 X 3/4 Hex Hd.) Brace to Wheelhouse	2
	121887	Bolt (1/4-20 X 3/4 Hex Hd.) Brace to Fender	4
	121887	Bolt (1/4-20 X 3/4 Hex Hd.) Fender to Floor Pan Brace	2
	121887	Bolt (1/4-20 X 3/4 Hex Hd.) Fender to Sill	2
	120392	Washer (9/32 ID X 5/8 OD Plain) Brace to Wheelhouse	2
	120392	Washer (9/32 ID X 5/8 OD Plain) Brace to Fender	4
	174916	LW (1/4 Int. Ext. Tooth) Brace to Wheelhouse	2
	174916	LW (1/4 Int. Ext. Tooth) Brace to Fender	4
	174916	LW (1/4 Int. Ext. Tooth) Fender to Floor Pan Brace	2
	174916	LW (1/4 Int. Ext. Tooth) Fender to Sill Brace to Wheelhouse	2
	120375	Nut (1/4-20 Hex) Brace to Wheelhouse	2
	634224	Seal - Rear Fender to Pillar	2
	189129	Screw (1/4-20 X 5/8 THCR) Fender to Pillar	8
	626516	LW (1/4 X .632 OD nt. Tooth) Fender to Pillar	8
	626403	Nut, Washer & Sealer (1/4-20) Fender to Body	16
	626919	Nut, Washer & Sealer (1/4-20) Fender to Body	4
		GLASS - REAR WINDOW	
9	644388	Glass - Rear Window - Clear	1
	644389	Glass - Rear Window - Tinted	1
10	644479	Weatherseal - Rear Window	1