

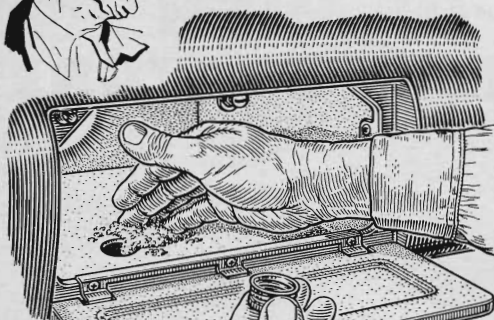

Hints from the Model Garage

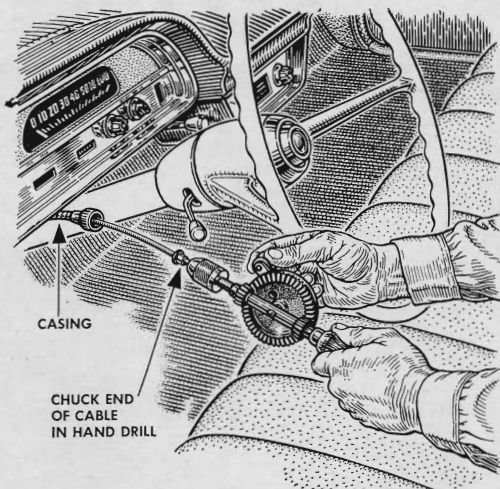

Handy cleanout. For easier cleaning of his glove compartment, one motorist has cut a hole in the bottom and fitted in a screw cap from a can of liquid wax. For cleaning, he removes the cap, sweeps dirt into a bag below the compartment.



Turn in that cable. It's usually difficult to slide a newly greased speedometer cable back into its casing. The job is easier this way: After starting the cable, chuck the end in a hand drill. Then turn the cable as you shove on it.

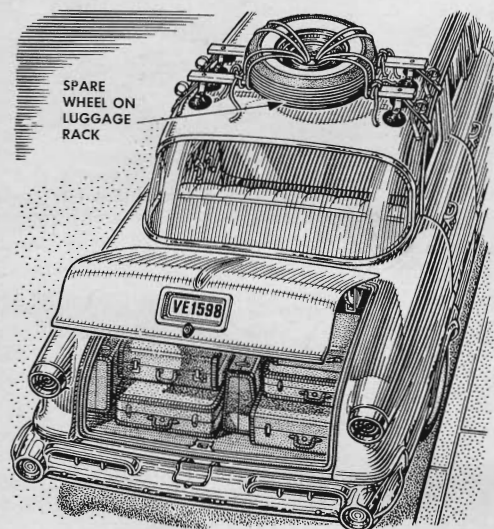

Touring tip. Said a lady passenger: "Since rain won't hurt the extra tire, why not put it on top of the car and use the whole rear deck for our suitcases?" A sensible idea—the bags are protected and the tire is as accessible as ever.



Distress signal. One car owner has made his own warning signals for use when he is forced to stop along the highway after dark. The picture shows how. Mailing tubes covered with reflective tape are slipped over the rear antennas.

More Hints from the Model Garage

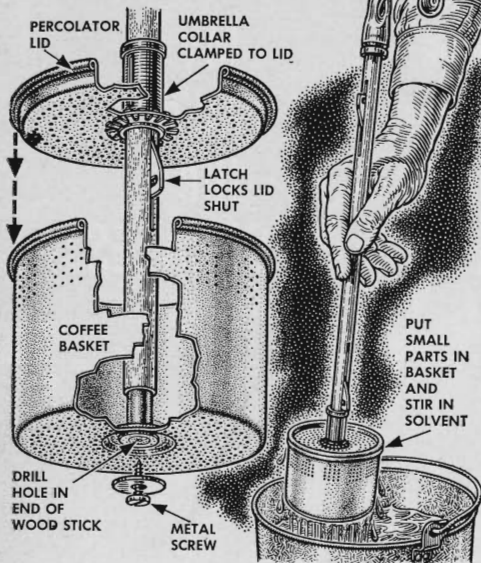

Small-parts washer. An old umbrella and the basket from a discarded coffee percolator are the main parts used in making this small-parts washer. Remove the stays from the umbrella collar and fit it into the percolator tube.

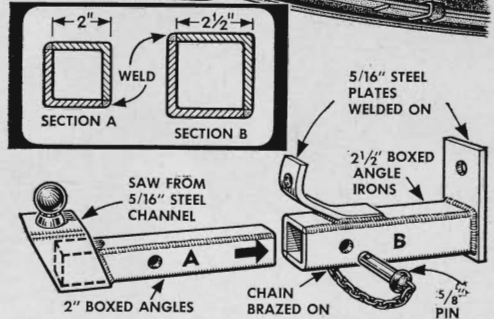
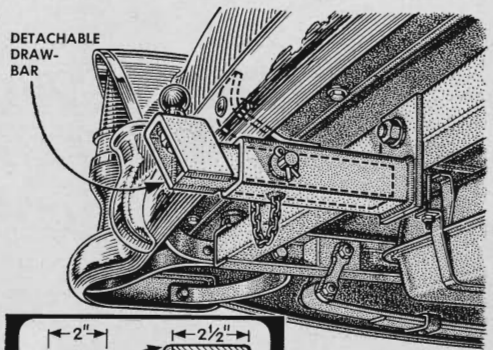

Detachable hitch. Here's a trailer hitch that's right there when you need it, but that's easily removed when you don't. It's best to weld up section B first, then use this as a form in making section A so that it slips nicely into B.

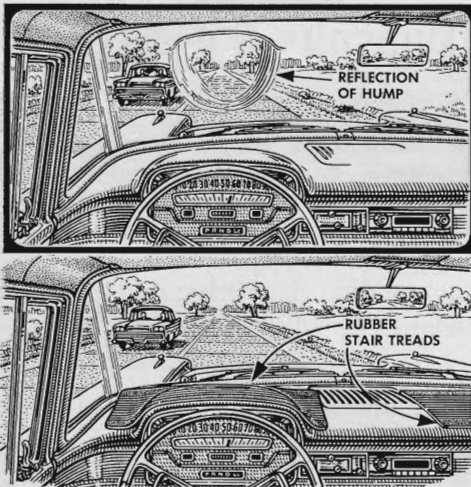

Overcoming glare. On some cars you get a disturbing sun reflection from the hump of the instrument panel. Draping a rubber stair tread over the hump is one way of overcoming this. A second piece can be put on the passenger side.

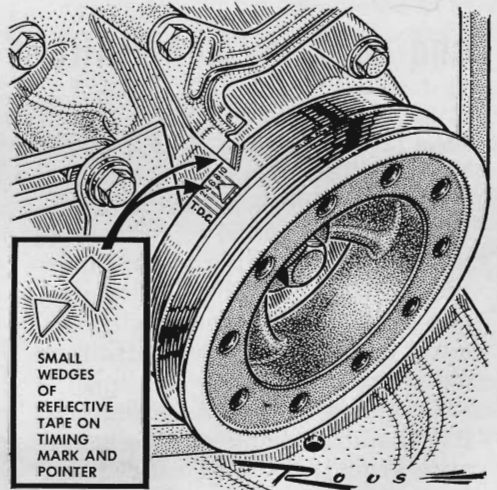

A timing tip. Ignition-timing marks often become so dirty that you have difficulty seeing them. When this happens, cut small wedge-shaped pointers from adhesive reflective tape (red is excellent) and press them into place.