

MORE Hints from the Model Garage

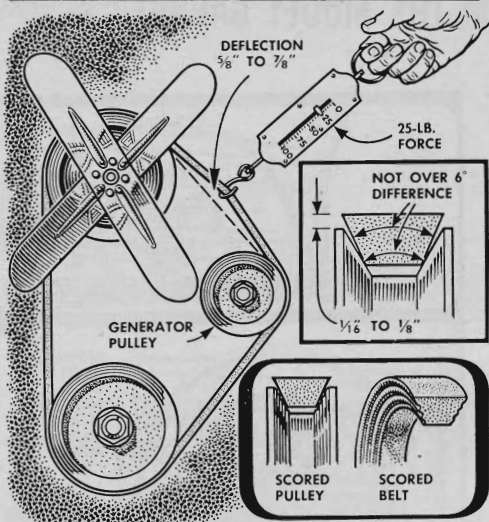

Fan-belt life may be shortened by any of the reasons indicated here. In installing a new belt, always make sure it is engineered (in cross section) to fit your particular pulleys. If a pulley is scored, your belt eventually will become scored too—and weakened. If too tight, the belt will damage water-pump and fan bearings.

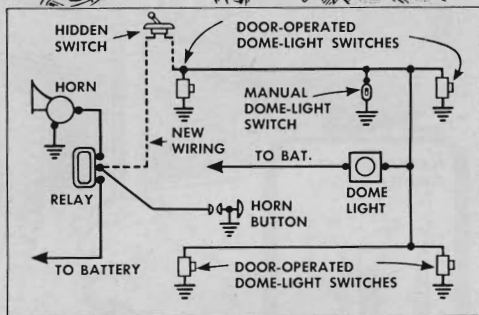

A simple and effective burglar alarm can be installed with a length of wire and a single-pole switch. Use the wire to connect the horn and courtesy-light circuits through the switch. If anyone opens the door, the horn will blow. Hide the switch somewhere on the exterior of the car so you can shut off the alarm system.



If static sparks crackle from your fingers when you slide into or out of a car equipped with plastic seat covers, try keeping your hand on the door handle until you are settled or out. This will carry off the charge from your body.

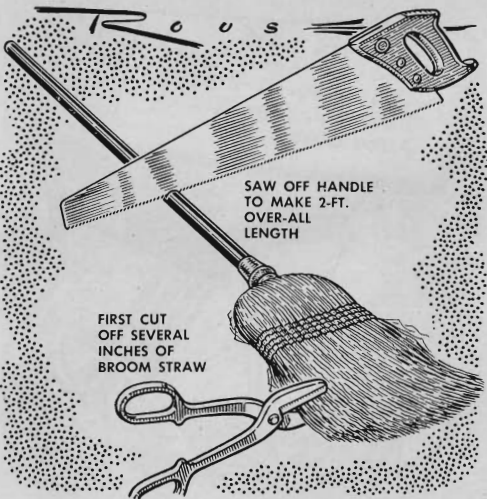

A handy brush for cleaning road dirt from the underside of a car can be made from a discarded household broom. Shorten the handle with a saw and snip about 6" off the bristles, leaving just enough so you'll have a brush that's good and stiff.